

## FITTING INSTRUCTION

Clamp mark in acc. with		Cables joining
ISO	PN	
1	L	Left directional lights
2	+	Rear fog lights
3	31	Ground
4	R	Right directional lights
5	58R	Right side parking lights
6	54	Stoptlights
7	58L	Left side parking lights

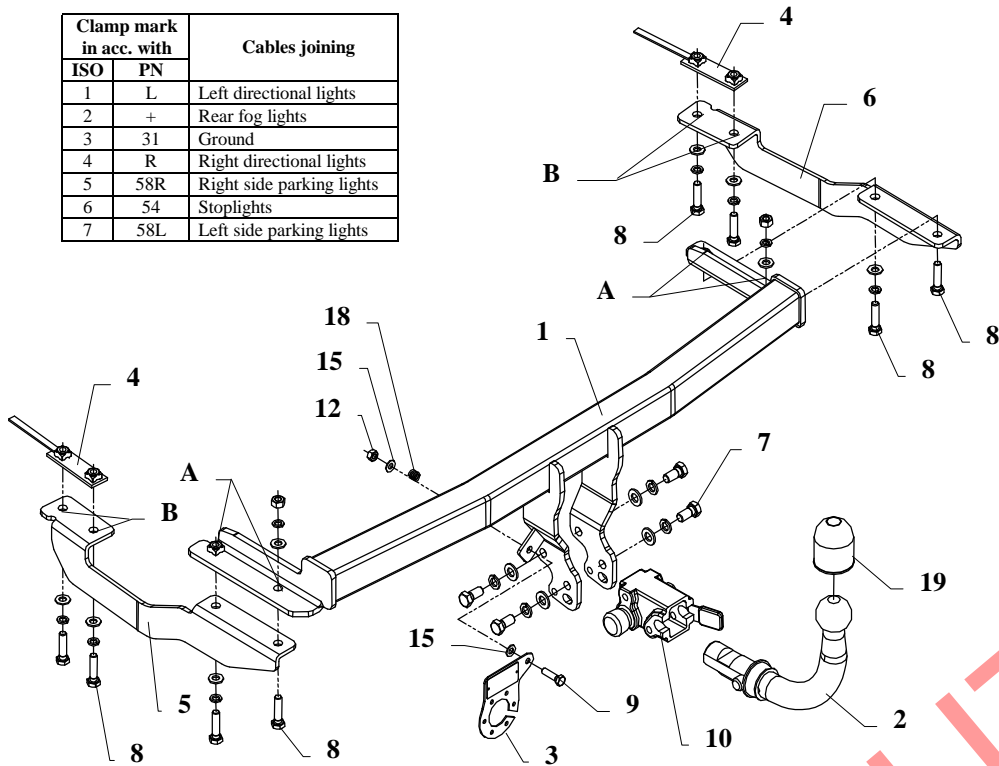

The towing hitch can be used in the following cars:

- **VW POLO Classic** produced since 1996 till 2000
- **VW POLO Variant** produced since 1997 till 2000
- **SEAT CORDOBA 2/4 door, CLX, GLX, GTI, SX, Coupe** produced since 02.1996 till 12.2002
- **SEAT CORDOBA Varrio** produced since 1997 till 12.2002

catalogue no. **K22A** and is prepared to tow trailers max total weight **1200kg** and max vertical load **50kg**.

### DE PRODUCATOR:

Vă mulțumim pentru achiziționarea produsului nostru. Fiabilitatea acestor produse a fost confirmată în numeroase teste. Fiabilitatea produselor depinde de asemenea și de asamblarea corectă și în ordinea specificată în aceste instrucțiuni. Din acest motive vă rugăm să citiți cu atenție instrucțiunile și să le urmați întocmai. Bara de tractare trebuie să fie instalată în punctele descrise de producătorul autovehiculului.

## The instruction of the assembly

1. Disassemble the bumper together with the bottom cover, then unscrew the metal bumper support (this part is not useful any more).
2. To chassis members tunnels slide the bar of towing hitch (pos. 1), and position it in such a way that holes (pos. A) are compatible with the chassis member's holes.
3. Position the supports (pos. 5 and 6) to the bottom car's part and fix it through holes (pos. A) with bolts M10x40mm (pos. 8) from accessories.
4. Through the supports holes (pos. B) drill holes  $\varnothing 12$  mm in the chassis members.
5. Put jibs with nuts (pos. 4) through the huge chassis member's holes and fix it with the supports through drilled holes using bolts M10x40mm
6. Cut the bumper and its cover (see supplied sketches).
7. Reassemble the bumper together with cover.
8. Fix body of the automat (pos. 10) using bolts M12x25mm (pos. 7) from accessories. Place tow-ball (pos. 2) according to supplied instruction.
9. Fix the socket plate (pos. 3) as shown on the drawing.
10. Tighten all nuts and bolts according to the torque shown in the table.
11. Connect the electric wires according to the instructions of the car.
12. Complete the paint cover of towing hitch (during the mounting paint cover could be destroyed).

Torque settings for nuts and bolts (8,8):

<b>M6</b> - 11 Nm	<b>M8</b> - 25 Nm	<b>M10</b> - 50 Nm
<b>M12</b> - 87 Nm	<b>M14</b> - 138 Nm	<b>M16</b> - 210 Nm











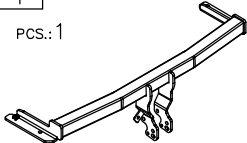
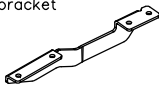

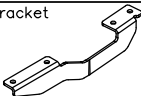

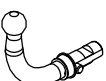

### NOTE

After install the towing hitch you should get adequate note in registration book (at authorised service station). The car should be equipped with:

- Indicators
- Tow mirrors

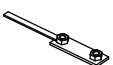
After 1000km of exploitation check all bolts and nuts. The ball of towing hitch must be always kept clear and conserve with a grease.

## Towing hitch accessories:

Pos. 1 Main bar PCS.: 1	Pos. 5 Left bracket PCS.: 1	Pos. 10 Body of the automat PCS.: 1	Pos. 15 Plain washer ø8mm PCS.: 2
			
	Pos. 6 Right bracket PCS.: 1	Pos. 11 Nut 8 B M10 PCS.: 2	Pos. 16 Spring washer ø12mm PCS.: 4
			
Pos. 2 Tow ball PCS.: 1	Pos. 7 Bolt 8,8 B M12x25mm PCS.: 4	Pos. 12 Nut 8 B M8 PCS.: 1	Pos. 17 Spring washer ø10mm PCS.: 8
			
Pos. 3 Socket plate PCS.: 1	Pos. 8 Bolt 8,8 B M10x40mm PCS.: 8	Pos. 13 Plain washer ø12mm PCS.: 4	Pos. 18 Spring PCS.: 1
			
Pos. 4 Jib with nuts PCS.: 2	Pos. 9 Bolt 8,8 B M8x30mm PCS.: 1	Pos. 14 Plain washer ø10mm PCS.: 8	Pos. 19 Ball cover PCS.: 1
			



S.C. AUTO GEDAL IMPEX S.R.L.

Tel: +40 745.805.990 / +40 737.122.471

Email: autogedal@gmail.com

office@auto-hak.ro

Web Page: www.auto-hak.ro

## Carlig remorcare Volkswagen Polo 1996-2000 demontabil automat Auto-Hak

Class: **A50-X** Cat. no. **K22A**

Designed for:

**VW POLO Classic**

produced since 1996 till 2000

**VW POLO Variant**

produced since 1997 till 2000

**SEAT CORDOBA**

**2/4 doors CLX, GLX, GTI, SX, Coupe**

produced since 02.1996 till 12.2002

**SEAT CORDOBA Vario**

produced since 1997 till 12.2002

**Approval number according to Directive 94/20/EC: e20\*94/20\*0407\*00**

Technical data:

**D-value: 6,70 kN**

maximum trailer weight: **1200 kg**

maximum vertical cup load: **50 kg**

Acesta bara de tractare este proiectata în conformitate cu normele de siguranță ale regulilor de circulație. Carligul de tractare este o componentă de siguranță și poate fi instalata numai de personal calificat. Orice modificare sau transformare facuta asupra cârligului de remorcare este interzisă și va duce la anularea certificării produsului. Indepartați materialul izolator de sub vehicul (dacă există) în zona de montare a ansamblului. Specificatiile de produs ale autovehiculului referitor la greutatea admisa pe vehicul, sunt extrem de importante. In acelasi timp, sarcina admisa pentru cârligul de remorcare nu poate fi depășită și poate fi calculata folosind relatia:

$$\frac{\text{Masa maxima a remorcii [kg]} \times \text{Masa maxima a masinii[kg]}}{\text{Masa maxima a remorcii [kg]} + \text{Masa maxima a masinii[kg]}} \times \frac{9,81}{1000} = D \text{ [kN]}$$