

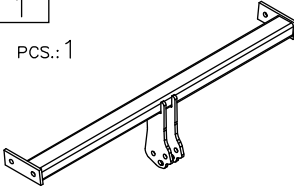

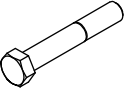







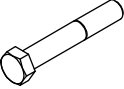

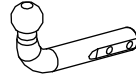

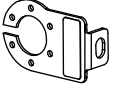
Towing hitch accessories:

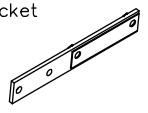
Pos. 1	Main bar 	Pos. 6	Bolt 8,8 B M12x75mm 	Pos. 12	Spring washer ø12,2mm 
PCS.: 1		PCS.: 1		PCS.: 6	
		Pos. 7	Bolt 8,8 B M12x70mm 	Pos. 13	Spring washer ø10,2mm 
		PCS.: 1		PCS.: 4	
Pos. 2	Tow ball 	Pos. 8	Bolt 8,8 B M12x35mm 	Pos. 14	Nut 8 B M12 
PCS.: 1		PCS.: 4		PCS.: 4	
Pos. 3	Socket plate 	Pos. 9	Bolt 8,8 B M10x40mm 	Pos. 15	Ball cover 
PCS.: 1		PCS.: 4		PCS.: 1	
Pos. 4	Right bracket 	Pos. 10	Plain washer ø13mm 		
PCS.: 1		PCS.: 6			
Pos. 5	Left bracket 	Pos. 11	Plain washer ø30xø10,5x2,5mm 		
PCS.: 1		PCS.: 4			

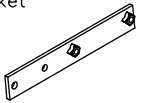
Carlig remorcare Volkswagen Fox 2005- semidemontabil Auto-Hak

Class: A50-X Cat. no. K50

Designed for:

Manufacturer: VOLKSWAGEN

Model: FOX

produced since 2005

Technical data:

D-value: 6,7 kN

maximum trailer weight: 1000 kg

maximum vertical cup mass: 50 kg

Approval number according to Directive 94/20/EC: e20*94/20*0578*00

Acesta bara de tractare este proiectata în conformitate cu normele de siguranță ale regulilor de circulație. Carligul de tractare este o componentă de siguranță și poate fi instalata numai de personal calificat. Orice modificare sau transformare facuta asupra cârligului de remorcare este interzisă și va duce la anularea certificării produsului. Indepartați materialul izolator de sub vehicul (dacă există) in zona de montare a ansamblului. Specificatiile de produs ale autovehiculului referitor la greutatea admisa pe vehicul, sunt extrem de importante. In acelasi timp, sarcina admisa pentru cârligul de remorcare nu poate fi depășită si poate fi calculata folosind relatia:

$$\frac{\text{Masa maxima a remorcii [kg]} \times \text{Masa maxima a masinii[kg]}}{\text{Masa maxima a remorcii [kg]} + \text{Masa maxima a masinii[kg]}} \times \frac{9,81}{1000} = D \text{ [kN]}$$

FITTING INSTRUCTION

Clamp mark in acc. with		Cables joining
ISO	PN	
1	L	Left directional lights
2	+	Rear fog lights
3	31	Ground
4	R	Right directional lights
5	58R	Right side parking lights
6	54	Stoplights
7	58L	Left side parking lights

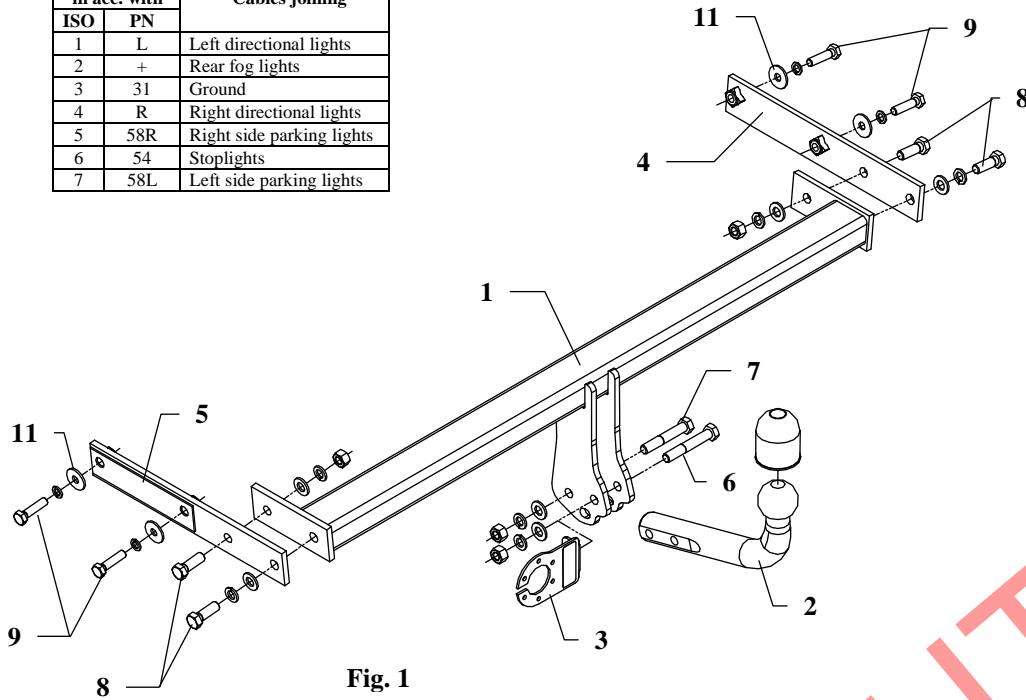

Fig. 1

This towing hitch is designed to assembly in following cars:
VOLKSWAGEN FOX, produced since 2005, catalogue no. **K50** and is prepared to tow trailers max total weight **1000 kg** and max vertical mass **50 kg**.

Torque settings for nuts and bolts (8,8):	
M 8 - 25 Nm	M 10 - 55 Nm
M 12 - 85 Nm	M 14 - 135 Nm

DE PRODUCATOR:

Vă mulțumim pentru achiziționarea produsului nostru. Fiabilitatea acestor produse a fost confirmată în numeroase teste. Fiabilitatea produselor depinde de asemenea și de asamblarea corectă și în ordinea specificată în aceste instrucțiuni. Din acest motive va rugăm să citiți cu atenție instrucțiunile și să le urmați întocmai. Bara de tractare trebuie să fie instalată în punctele descrise de producătorul autovehiculului.

The towing hitch should be install in points described by a car producer.

The instruction of the assembly

1. Disassemble bumper with metal reinforcement. Reinforcement will not used any more.
2. Inside chassis members slip suitable side brackets (pos. 4 and 5) in this way, so holes of brackets agree with factory prepared holes in chassis members. Fix loosely using bolts M10x40mm (pos. 9) as shown on figure 1.
3. Between installed side brackets slip main bar of the towbar (pos. 1) and fix using bolts M12x35mm (pos. 8) as shown on figure 1.
4. Reassemble bumper after cut out it's fragment according to figure 2.
5. Fix tow-ball (pos. 2) with socket plate (pos. 3) using bolts M12x75mm (pos. 6) and M12x70mm (pos. 7) from accessories.
6. Tighten all bolts according to the torque shown in the table.
7. Connect electric wires of 7-poles socket according to the instruction of the car. (Recommend to make at authorized service station).
8. Complete paint layer damaged during installation.

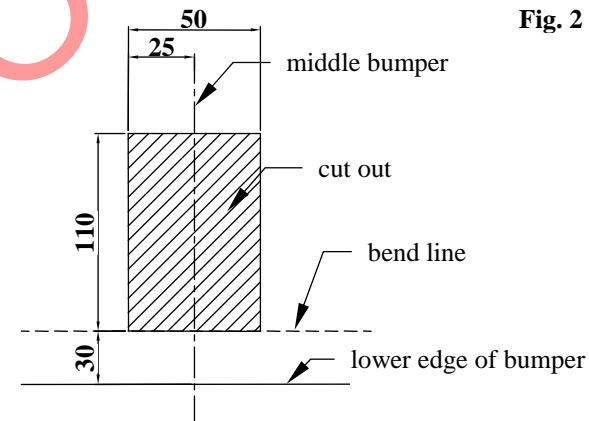
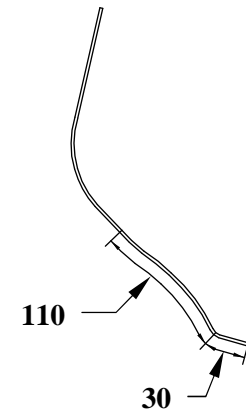

Fig. 2



NOTE

After install the towing hitch you should get adequate note in registration book (at authorised service station). The car should be equipped with:

- Indicators
- Tow mirrors

After 1000km check all bolts and nuts. The ball of towing hitch must be always kept clear and conserve with a grease.