

FITTING INSTRUCTION

Clamp mark in acc. with		Cables joining
ISO	PN	
1	L	Left directional lights
2	+	Rear fog lights
3	31	Ground
4	R	Right directional lights
5	58R	Right side parking lights
6	54	Stoplights
7	58L	Left side parking lights

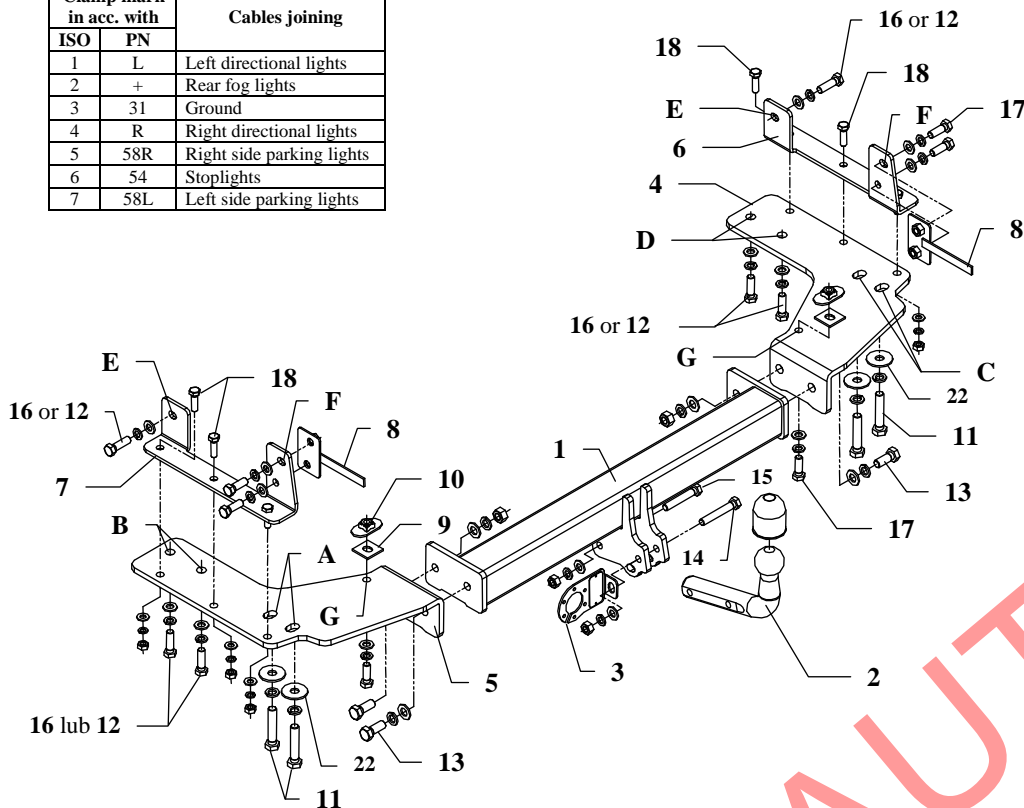

This towing hitch is designed to assembly in following cars: **TOYOTA LANDCRUISER (J100)**, produced since 1998 till 12.2002, catalogue no. **O35** and is prepared to tow trailers max total weight **3500 kg** and max vertical load **120 kg**.

DE PRODUCATOR:

Vă mulțumim pentru achiziționarea produsului nostru. Fiabilitatea acestor produse a fost confirmată în numeroase teste. Fiabilitatea produselor depinde de asemenea și de asamblarea corectă și în ordinea specificată în aceste instrucțiuni. Din acest motive va rugăm să citiți cu atenție instrucțiunile și să le urmați întocmai. Bara de tractare trebuie să fie instalată în punctele descrise de producătorul autovehiculului.

The towing hitch should be install in points described by a car producer.

The instruction of the assembly

1. Disassemble original towing handles. Disassemble metal part of the bumper (reinforcement), it will be not used any more.
2. To the left chassis member put left bracket (pos. 5) and fix it together with disassembled towing eye through holes **A** using bolts M14x1,5x70mm (pos. 11) and through holes **B** using bolts M12x1,25x40mm (pos. 16)-loosely.
NOTE !!! In some models it could be bolts M14x1,5x50mm (pos. 12).
3. To the right chassis members put right bracket (pos. 4) and fix it together with disassembled towing eye through holes **C** using bolts M14x1,5x70mm (pos. 11) and through holes **D** using bolts M12x1,25x40mm (pos. 16)-loosely.
NOTE !!! In some models it could be bolts M14x1,5x50mm (pos. 12).
4. To the prepared side brackets put left fish-plate pos. 7 (to the left member) and right fish-plate pos. 6 (to the right member) as shown in the drawing and fix using bolts M10x35mm (pos. 18). Next through holes **E** fix all using bolts M12x1,25x40mm (pos. 16) or in some models M14x1,5x50mm (pos. 12).
5. To fix side brackets through holes **F** use jibs with nuts pos. 8 and bolts M12x35mm (pos. 17).
6. Through holes **G** (in brackets 4 and 5) drill holes in only one side of the car frame using bit $\varnothing 12,5\text{mm}$. Next fix using bolts M12x35mm (pos. 17) and square washers pos. 9 (put between frame and side brackets) and washers with nuts pos. 10.
7. Between installed side brackets put main bar of the towbar (pos. 1) and fix it using bolts M14x35mm (pos. 13)
8. Fix tow-ball (pos. 2) with socket plate (pos. 3) using bolts M12x75mm (pos. 14) and M12x70mm (pos. 15) from accessories.
9. Tighten all bolts according to the torque shown in the table.
10. Connect electric wires of 7-poles socket according to the instruction of the car. (Recommend to make at authorized service station).
11. Complete paint layer damaged during installation.

Torque settings for nuts and bolts (8,8):

M6 - 11 Nm	M8 - 25 Nm	M10 - 50 Nm
M12 - 87 Nm	M14 - 138 Nm	M16 - 210 Nm











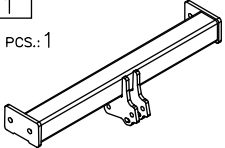

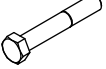

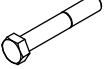



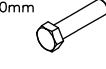



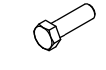

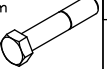
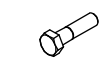
NOTE

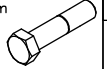
After installation of the towing hitch you should get adequate note in registration book (at authorised service station). The car should be equipped with:

- Indicators
- Tow mirrors

After 1000km of exploitation check all bolts and nuts. The ball of towing hitch must be always kept clear and conserve with a grease.

Part list:

Pos. 1 Main bar PCS.: 1 	Pos. 7 Left fish-plate PCS.: 1 	Pos. 14 Bolt 8,8 B M12x75mm PCS.: 1 	Pos. 22 Plain washer ø44xø15x3mm PCS.: 4 
	Pos. 8 Fish-plate with nuts PCS.: 2 	Pos. 15 Bolt 8,8 B M12x70mm PCS.: 1 	Pos. 23 Plain washer ø15mm PCS.: 10 
Pos. 2 Tow ball PCS.: 1 	Pos. 9 Square washer PCS.: 2 	Pos. 16 Bolt 8,8 B M12x1,25x40mm PCS.: 6 	Pos. 24 Plain washer ø13mm PCS.: 14 
Pos. 3 Socket plate PCS.: 1 	Pos. 10 Washer with nut PCS.: 2 	Pos. 17 Bolt 8,8 B M12x35mm PCS.: 6 	Pos. 25 Plain washer ø10,5mm PCS.: 6 
Pos. 4 Right bracket PCS.: 1 	Pos. 11 Bolt 8,8 B M14x1,5x70mm PCS.: 4 	Pos. 18 Bolt 8,8 B M10x35mm PCS.: 6 	Pos. 26 Spring washer ø14,2mm PCS.: 14 
Pos. 5 Left bracket PCS.: 1 	Pos. 12 Bolt 8,8 B M14x1,5x50mm PCS.: 6 	Pos. 19 Nut 8 B M14 PCS.: 2 	Pos. 27 Spring washer ø12,2mm PCS.: 14 
Pos. 6 Right fish-plate PCS.: 1 	Pos. 13 Bolt 8,8 B M14x35mm PCS.: 4 	Pos. 20 Nut 8 B M12 PCS.: 2 	Pos. 28 Spring washer ø10,2mm PCS.: 6 
		Pos. 21 Nut 8 B M10 PCS.: 6 	Pos. 29 Ball cover PCS.: 1 



Tel: +40 745.805.990 / +40 737.122.471
 Email: autogedal@gmail.com
 office@auto-hak.ro
 Web Page: www.auto-hak.ro

Carlig remorcare Toyota Landcruiser 1998-2002 semidemontabil Auto-Hak

Class: **A50-X** Cat. no. **035**

Designed for:

Manufacturer: **TOYOTA**

Model: **LANDCRUISER**

Type: **J100**

produced since 1998 till 12.2002

Technical data:

D-value: 16,6 kN

maximum trailer weight: **3500 kg**

maximum vertical cup load: **120 kg**

Approval number according to Directive 94/20/EC: e20*94/20*0266*00

Acesta bara de tractare este proiectata în conformitate cu normele de siguranță ale regulilor de circulație. Carligul de tractare este o componentă de siguranță și poate fi instalata numai de personal calificat. Orice modificare sau transformare facuta asupra cârligului de remorcare este interzisă și va duce la anularea certificării produsului. Indepartați materialul izolator de sub vehicul (dacă există) in zona de montare a ansamblului. Specificatiile de produs ale autovehiculului referitor la greutatea admisa pe vehicul, sunt extrem de importante. In acelasi timp, sarcina admisa pentru cârligul de remorcare nu poate fi depășită si poate fi calculata folosind relatia:

$$\frac{\text{Masa maxima a remorcii [kg]} \times \text{Masa maxima a masinii[kg]}}{\text{Masa maxima a remorcii [kg]} + \text{Masa maxima a masinii[kg]}} \times \frac{9,81}{1000} = D \text{ [kN]}$$