



04.2010 -

## RENAULT MASTER

Cat. No. **R/046**

e20

e20\*94/20\*1479\*00

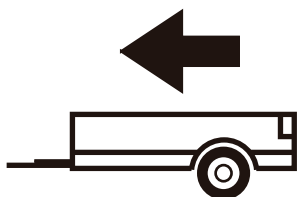

3000kg

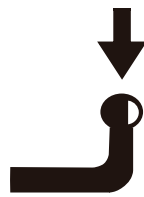

100kg

**D** = 14,30kN

**D (kN) =**



MAX kg

x

MAX kg

x 0,00981



MAX kg

+

MAX kg



IMIOLA HAK-POL

96-111 KOWIESY, CHOJNATA 23A, POLAND

Tel. + 48 46 831 73 31, fax +48 831 74 29

e-mail: office@imiola.pl, www.imiola.pl

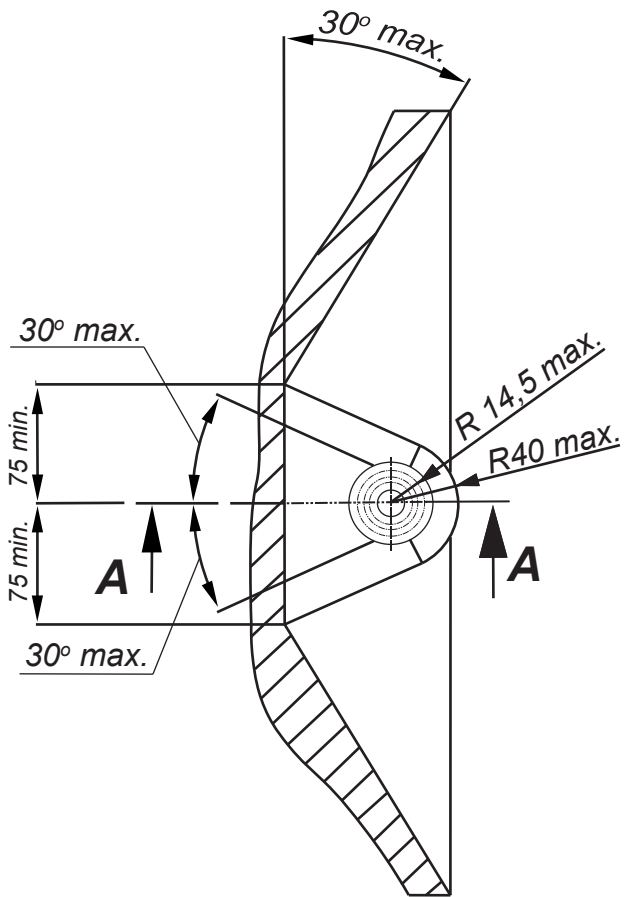

**PRZEKRÓJ A-A**

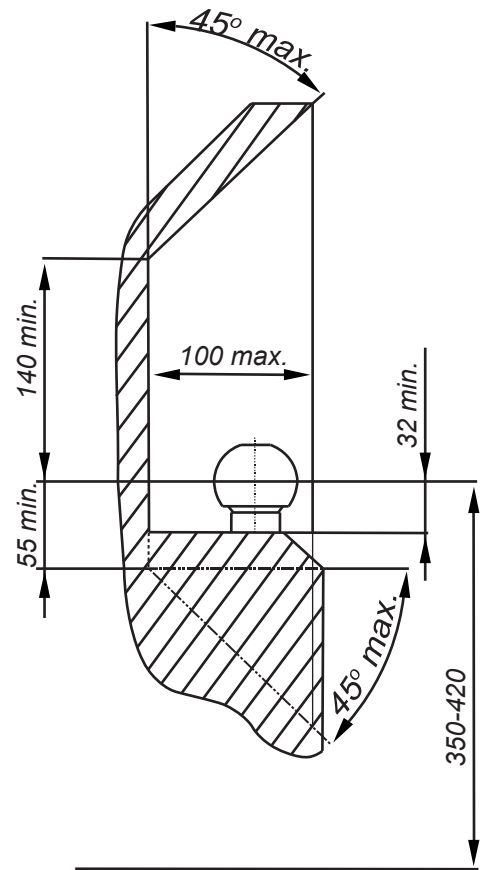

**PL** Należy zagwarantować przestrzeń swobodną według załącznika VII, rysunek 25a/b Regulaminu EKG ONZ 55.01 przy dopuszczalnym ciężarze całkowitym pojazdu.

**F** L'espace libre doit être garanti conformément à l'annexe VII, illustration de la réglementation 55.01 CE pour un poids total en charge autorisé du véhicule.









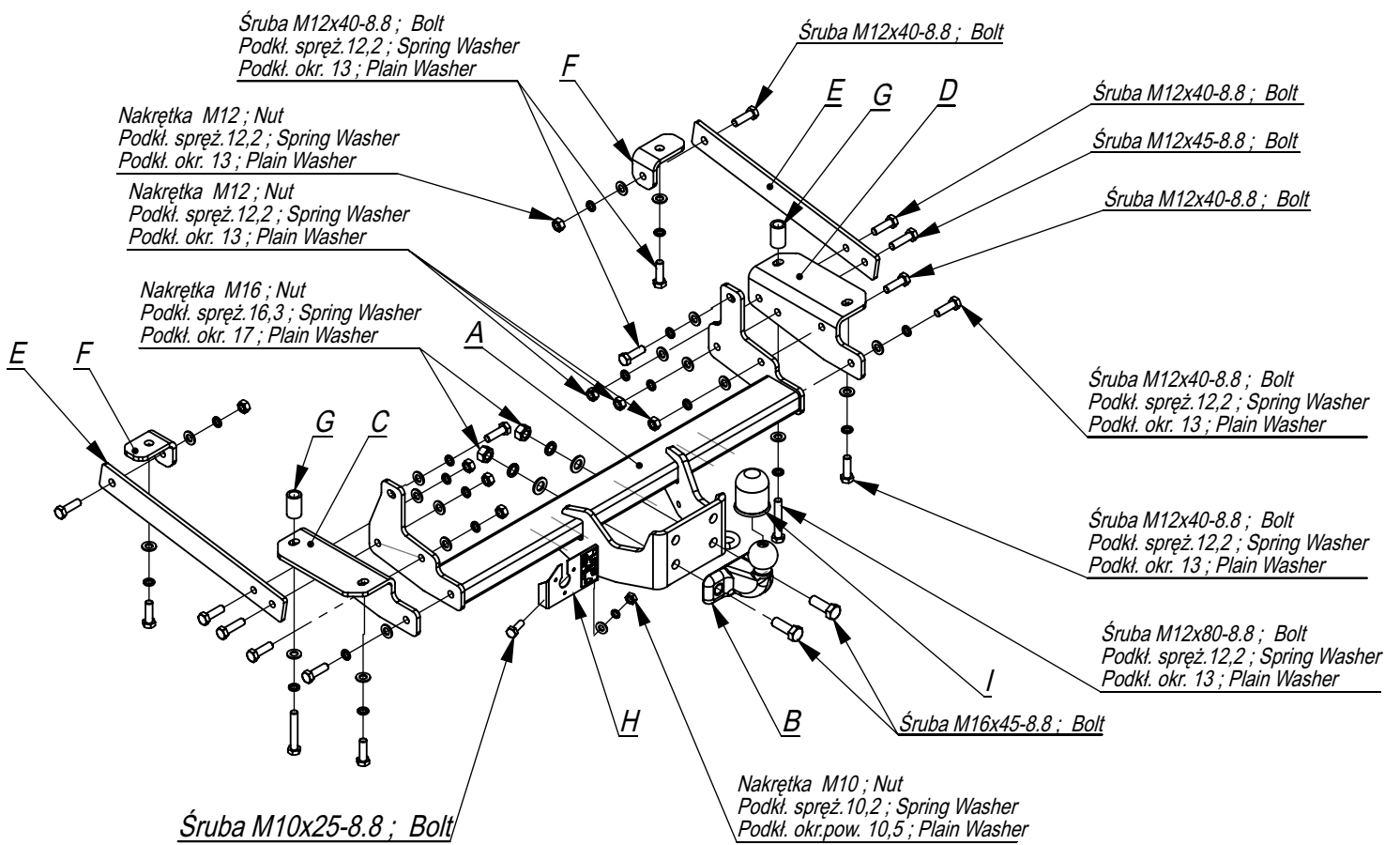

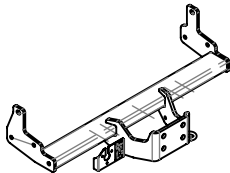
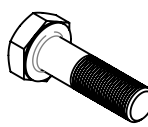

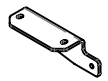
**GB** The clearance specified in appendix VII, diagram 25a/b of Regulation No. 55.01 UN EU must be guaranteed at laden weight of the vehicle.

**D** Der Freiraum nach Anhang VII, Abbildung 25a/b der Vorschriften 55.01 EG ist zu gew 25a/bahrleisten bei zulässigem Gesamtgewicht des Fahrzeuges.

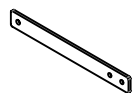
Moment skręcający dla śrub i nakrętek (8.8) Torque settings for nuts and bolts (8.8)	
M8	25Nm
M10	55Nm
M12	85Nm
M14	135Nm
M16	195Nm





	A	x1		M16x45	2
				M12x80	2
				M12x45	2
				M12x40	14
				M10x25	1
	B	x1		M16	2
				M12	8
	C	x1		M10	1
				17	2
	D	x1		13	18
				16,3	2
	E	x2		12,2	18
				10,2	1
				Ø30xØ10,5x3	1
	F	x2			
	G	x2			
	H	x1			
	I	x1			

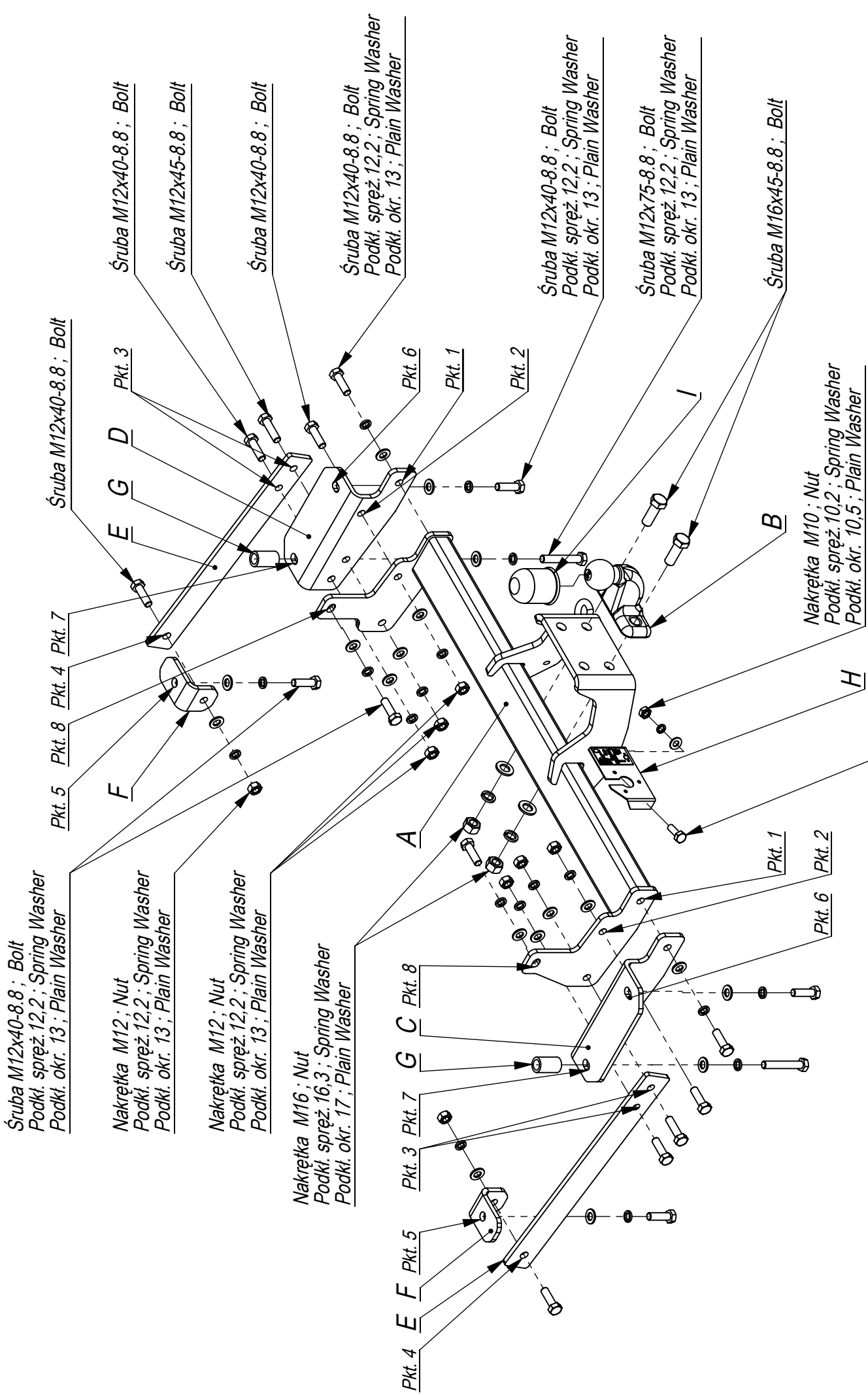

96-111 Kowiesy, Chojnata 23 A  
tel. +48 46 831 73 31

Nr katalogowy Marka  
 R/046 Renault Master, Opel Movano FWD od 2010 ->  
 Nissan Nv 400/Fiat Talento od 2011 ->

- Odkręcamy fabryczne ucho holownicze.
- Elementy C i D przykręcamy lekko do podwozia śrubami M12x80 8.8 (pkt 7), M12x40 8.8 (pkt 6) wraz z tulejkami.
- Elementy F przykręcamy do podwozia śrubami M12x40 8.8 (pkt 5).
- Belkę haka A wsuwamy między elementy i przykręcamy śrubami M12x40 8.8 (pkt 1,2,8).
- Następnie elementy E przykręcamy do elementów F, C i D śrubami M12x40 8.8 ( pkt 4,3)
- Dokręcić wszystkie śruby z momentem według tabeli.
- Dokręcić kulę i blachę gniazda elektrycznego.
- Podłączyć instalację elektryczną.

- Unscrew the towing eye.
- Screw slightly the elements C and D to the chassis with bolts M12x80 8.8 (point 7) and M12x40 8.8 (point 6)
- together with the distance sleeves.
- Screw the elements F to the chassis with bolts M12x40 8.8 (point 5).
- Insert the main bar A between the elements C and D and screw with bolts M12x40 8.8 (points 1, 2, 8).
- Screw the elements E to the elements C, D and F with bolts M12x40 8.8 (point 3 and 4).
- Tighten all the bolts according to the torque setting- see the table.
- Fix the towball and electric plate.
- Connect the electric wires.

- Dévisser l'anneau d'attelage.
- Serrer légèrement les éléments C et D au châssis à l'aide des boulons M12x80 8.8 (point 7), M12x40 8.8 (point 6) avec les douilles.
- Serrer les éléments F au châssis avec les vis M12x40 8.8 (point 5).
- Insérer la poutre du crochet A entre les éléments et visser avec les boulons M12x40 8.8 (point 1,2,8).
- Ensuite serrer les éléments E aux éléments F,C et D ? l'aide des boulons M12x40 8.8 (point 4,3).
- Serrer tous les boulons avec un couple de serrage selon tableau.
- Visser le crochet d'attelage et socle de prise électrique.
- Raccorder le circuit électrique.

- Die vom Werk aus vorhandenen Abschleppöse abschrauben.
- Die Tragteile C und D ans Gestell mit den Schrauben M12x80 8.8 (Punkt 7), M12x40 8.8 Punkt 6 mit den Hülsen locker anschrauben.
- Die Tragteile F ans Gestell mit den Schrauben M12x40 8.8 (Punkt 5) anschrauben.
- Den Querbalken A zwischen die Tragteile schieben und mit den Schrauben M12x40 8.8 (Punkt 1,2,8) anschrauben.
- Die Tragteile E an die Tragteile F, C, D mit den Schrauben M12x40 8.8 (Punkt 4,3) anschrauben.
- Alle Schrauben mit dem in der Tabelle angegebenen Drehmoment festziehen.
- Die Kugel und die Steckdosenhalterung anschrauben.
- Die Elektroinstallation anschließen.

- Desenrosque la argolla de remolque.
- Fijar ligeramente los elementos C y D al elemento longitudinal junto con los elementos G con los pernos M12x40 8.8 (puntos 6) y los pernos M12x80 (punto 7) .
- Fijar los elementos F a los largueros con tornillos M12x40 8.8 (punto 5).
- Apretar la barra del gancho A com tornillos M12x40 8.8 (punto 1,2,8).
- A continuación, fijar los elementos F,C,D y elementos E con los tornillos M12x40 8.8 (punto 4,3).
- Apretar todos los tornillos con el par según la tabla anterior.
- Apretar la bola y la placa de la toma eléctrica.
- Conectar la instalación eléctrica

