

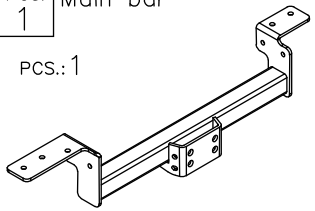

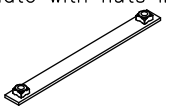







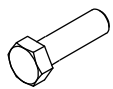

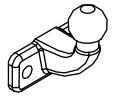
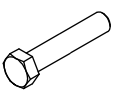

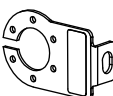
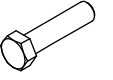
Part list:

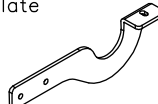
Pos. 1 Main bar PCS.: 1 	Pos. 7 Fish-plate with nuts II pcs.: 1 	Pos. 14 Plain washer ø10,5mm PCS.: 6 
	Pos. 8 Bolt 8,8 B M16x50mm PCS.: 2 	Pos. 15 Spring washer ø16,3mm PCS.: 2 
Pos. 2 Tow ball pcs.: 1 	Pos. 9 Bolt 8,8 B M12x50mm PCS.: 1 	Pos. 16 Spring washer ø12,2mm PCS.: 5 
Pos. 3 Socket plate pcs.: 1 	Pos. 10 Bolt 8,8 B M12x35mm PCS.: 4 	Pos. 17 Spring washer ø10,2mm PCS.: 6 
Pos. 4 Socket plate pcs.: 1 	Pos. 11 Bolt 8,8 B M10x30mm PCS.: 6 	Pos. 18 Nut 8 B M16 PCS.: 2 
Pos. 5 Left bracket pcs.: 1 	Pos. 12 Plain washer ø17mm PCS.: 2 	Pos. 19 Nut 8 B M12 PCS.: 6 
Pos. 6 Fish-plate with nuts I pcs.: 1 	Pos. 13 Plain washer ø13mm PCS.: 5 	Pos. 20 Ball cover PCS.: 1 

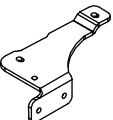

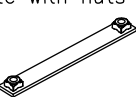
Tel: +40 745.805.990 / +40 737.122.471

Email: autogedal@gmail.com

office@auto-hak.ro

Web Page: www.auto-hak.ro

Carlig remorcare Suzuki Samurai 1982- semidemontabil Auto-HakClass: **A50-X** Cat. no. **W06**

Designed for:

Manufacturer: **SUZUKI**Model: **SAMURAI / SJ**

produced since 1982

Technical data:

D-value: 6,5 kNmaximum trailer weight: **1300 kg**maximum vertical cup mass: **75 kg****Approval number acc. to regulations EKG/ONZ 55.01: E20-55R-01**

Acesta bara de tractare este proiectata în conformitate cu normele de siguranță ale regulilor de circulație. Carligul de tractare este o componentă de siguranță și poate fi instalata numai de personal calificat. Orice modificare sau transformare facuta asupra cârligului de remorcare este interzisă și va duce la anularea certificării produsului. Indepartați materialul izolator de sub vehicul (dacă există) in zona de montare a ansamblului. Specificatiile de produs ale autovehiculului referitor la greutatea admisa pe vehicul, sunt extrem de importante. In acelasi timp, sarcina admisa pentru cârligul de remorcare nu poate fi depășită si poate fi calculata folosind relatia:

$$\frac{\text{Masa maxima a remorcii [kg]} \times \text{Masa maxima a masinii[kg]} \times \frac{9,81}{1000}}{\text{Masa maxima a remorcii [kg]} + \text{Masa maxima a masinii[kg]}} = D \text{ [kN]}$$

FITTING INSTRUCTION

Clamp mark in acc. with		Cables joining
ISO	PN	
1	L	Left directional lights
2	+	Rear fog lights
3	31	Ground
4	R	Right directional lights
5	58R	Right side parking lights
6	54	Stoptlights
7	58L	Left side parking lights

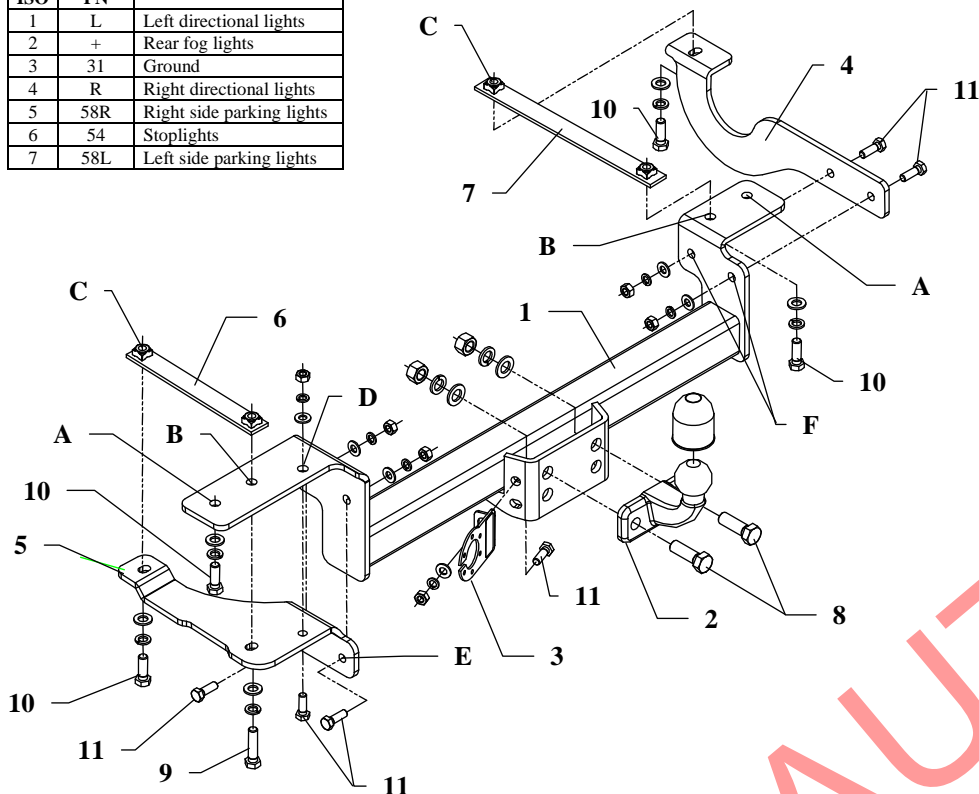

This towing hitch is designed to assembly in following cars:
SUZUKI SAMURAI / SJ, produced since 1982, catalogue number **W06**
 and is prepared to tow trailers max total weight up to **1300 kg** and max
 vertical mass **75 kg**.

DE PRODUCATOR:

Vă mulțumim pentru achiziționarea produsului nostru. Fiabilitatea acestor produse a fost confirmată în numeroase teste. Fiabilitatea produselor depinde de asemenea și de asamblarea corectă și în ordinea specificată în aceste instrucțiuni. Din acest motive vă rugăm să citiți cu atenție instrucțiunile și să le urmați întocmai. Bara de tractare trebuie să fie instalată în punctele descrise de producătorul autovehiculului.

The towing hitch should be installed in points described by a car producer.

The instruction of the assembly

1. Disassemble rear bumper together with lights (to get access to chassis members).
2. Disassemble original towing eye (keep one bolt for future installation).
3. Put main bar of the towbar (pos. 1) underneath to chassis frame and through holes pos. A and holes existing in frame's handle fix on the left side by bolt M12x35mm (pos. 10) and on the right side by bolt disassembled from original towing eye (see point 2).
4. Put suitable fish-plates with nuts (pos. 6 and 7) at points B, mark holes pos. C (in axis of the frame) and next drill holes using bit $\varnothing 13\text{mm}$.
5. On the left side put fish-plate with nuts I (pos. 6) into the chassis frame and put left bracket (pos. 5) to main bar and fix by bolt M12x50mm (pos. 9) through hole pos. B.
6. Fix left bracket through holes pos. D and E by bolts M10x30mm (pos. 11) and then through hole pos. C by bolt M12x35mm (pos. 10).
7. On the right side put fish-plate with nuts II (pos. 7) and fix with main bar through hole pos. B using bolt M12x35mm (pos. 10).
8. Put right bracket (pos. 4) to main bar and through holes pos. F fix using bolts M10x30mm (pos. 11) and then fix using bolt M12x35mm (pos. 10) through hole C with chassis member.
9. Assemble bumper to towing hitch using original bolts and nuts.
10. Fix tow-ball (pos. 2) using bolts M16x50mm (pos. 8) from equipment.
11. Fix socket plate (pos. 3) by bolt M10x30mm (pos. 411 as shown on the figure).
12. Tighten all bolts according to the torque shown in the table.
13. Connect electric wires of 7-poles socket according to the instruction of the car. (Recommend to make at authorized service station).
14. Complete paint layer damaged during installation.

Torque settings for nuts and bolts (8,8):

M6 - 11 Nm	M8 - 25 Nm	M10 - 50 Nm
M12 - 87 Nm	M14 - 138 Nm	M16 - 210 Nm

NOTE

After installation of the towing hitch you should get adequate note in registration book (at authorised service station). The car should be equipped with:

- Indicators
- Tow mirrors

Check all bolts and nuts after **1000 km** of exploitation. The ball of the towing hitch must be always kept clear and conserve with a grease.