

## FITTING INSTRUCTION

Clamp mark in acc. with		Cables joining
ISO	PN	
1	L	Left directional lights
2	+	Rear fog lights
3	31	Ground
4	R	Right directional lights
5	58R	Right side parking lights
6	54	Stoplights
7	58L	Left side parking lights

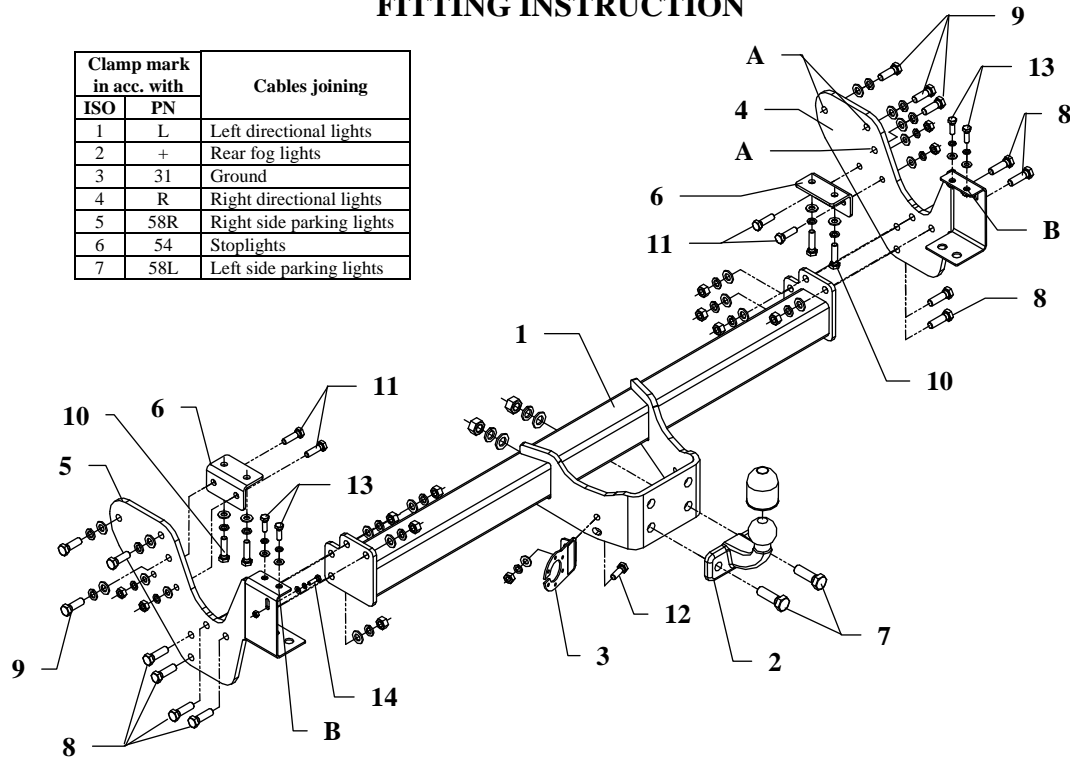

This towing hitch is designed to assembly in following car: **ISUZU D-MAX, bumper with a step**, produced since 01.2007 till 05.2012, catalogue number **IS01** and is prepared to tow trailers max total weight **3000 kg** and max vertical mass **120 kg**.

Torque settings for nuts and bolts (8,8):

<b>M6</b> - 11 Nm	<b>M8</b> - 25 Nm	<b>M10</b> - 50 Nm
<b>M12</b> - 87 Nm	<b>M14</b> - 138 Nm	<b>M16</b> - 210 Nm

### From manufacturer

Thank you for buying our product. Their reliability has been confirmed in many tests. Reliability of towing hitch depends also on correct assembly and right operation. For this reasons we kindly ask to read carefully this instruction and apply to hints.

*The towing hitch should be install in points described by a car producer.*

## The instruction of the assembly

1. Lower the spare wheel.
2. Disassemble plastic cover of the bumper, the bumper and rear fog light.
3. Disassemble brackets of the bumper (not used any more).
4. Fix side brackets (pos. 4 and 5) through points A by bolts M12x1,25x35mm (pos. 9) as shown in the drawing.
5. Apply suitable angle bars (pos. 6) and fix it loosely to a car by bolts M10x1,25x40mm (pos. 10) and to the mounted side brackets by bolts M10x35mm (pos. 11), see the drawing.
6. Between installed elements put main bar of the towbar and fix using bolts M12x40mm (pos. 8).
7. Reassemble bumper at points B using bolts M8x25mm (pos. 13).
8. Reassemble plastic cover of the bumper.
9. Reassemble rear fog light as shown in the drawing 2 using bolt M6x20mm (pos. 14).
10. Fix tow-ball (pos. 2) by bolts M16x50mm (pos. 7).
11. Fix socket plate (pos. 3) using bolt M10x30mm (pos. 12) from accessories.
12. Tighten all bolts according to the torque shown in the table.
13. Connect electric wires of 7-poles socket according to the instruction of the car. (Recommend to make at authorized service station).
14. Complete paint layer damaged during installation.

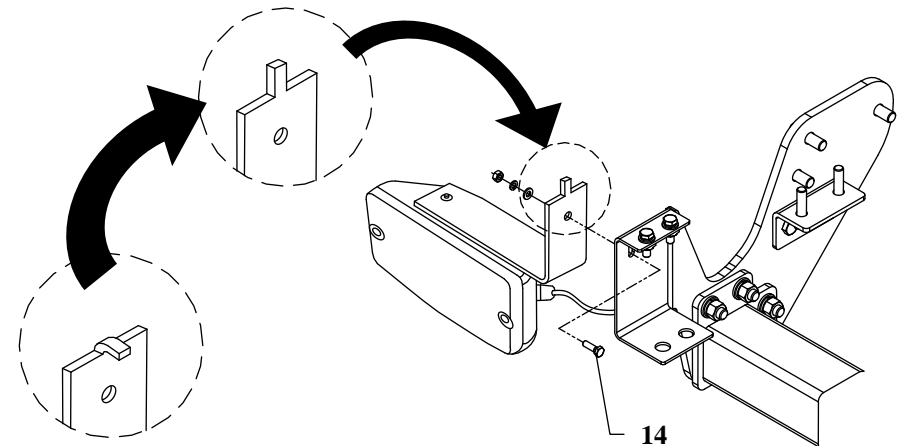











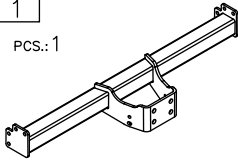
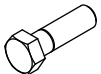

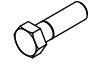



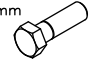



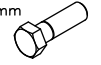



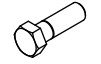

### NOTE

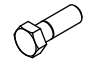
After install the towing hitch you should get adequate note in registration book (at authorised service station). The car should be equipped with:

- Indicators
- Tow mirrors

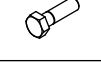
After 1000km of exploitation check all bolts and nuts. The ball of towing hitch must be always kept clear and conserve with a grease.

## Towing hitch accessories:

Pos. 1 Main bar PCS.: 1 	Pos. 7 Bolt 8,8 B M16x50mm PCS.: 2 	Pos. 14 Bolt 8,8 B M6x20mm PCS.: 1 	Pos. 22 Plain washer ø8.4mm PCS.: 4 
	Pos. 8 Bolt 8,8 B M12x40mm PCS.: 8 	Pos. 15 Nut 8 B M16 PCS.: 2 	Pos. 23 Plain washer ø6.4mm PCS.: 1 
Pos. 2 Tow ball PCS.: 1 	Pos. 9 Bolt 8,8 B M12x1.25x35mm PCS.: 6 	Pos. 16 Nut 8 B M12 PCS.: 8 	Pos. 24 Spring washer ø16.3mm PCS.: 2 
Pos. 3 Socket plate PCS.: 1 	Pos. 10 Bolt 8,8 B M10x1.25x40mm PCS.: 4 	Pos. 17 Nut 8 B M10 PCS.: 5 	Pos. 25 Spring washer ø12.2mm PCS.: 14 
Pos. 4 Right bracket PCS.: 1 	Pos. 11 Bolt 8,8 B M10x35mm PCS.: 4 	Pos. 18 Nut 8 B M6 PCS.: 1 	Pos. 26 Spring washer ø10.2mm PCS.: 9 
Pos. 5 Left bracket PCS.: 1 	Pos. 12 Bolt 8,8 B M10x30mm PCS.: 1 	Pos. 19 Plain washer ø17mm PCS.: 2 	Pos. 27 Spring washer ø8.2mm PCS.: 4 
Pos. 6 Angle fish-plate PCS.: 2 	Pos. 13 Bolt 8,8 B M8x25mm PCS.: 4 	Pos. 20 Plain washer ø13mm PCS.: 14 	Pos. 28 Spring washer ø6.1mm PCS.: 1 
		Pos. 21 Plain washer ø10.5mm PCS.: 9 	Pos. 29 Ball cover PCS.: 1 



**PPUH AUTO-HAK S.J.**

Produkcja Zaczepów Kulowych  
Henryk i Zbigniew Nejman  
76-200 SŁUPSK ul. Słoneczna 16K  
tel/fax (059) 8-414-414; 8-414-413  
E-mail: [office@autohak.com.pl](mailto:office@autohak.com.pl)  
[www.autohak.com.pl](http://www.autohak.com.pl)

## Towing hitch (without electrical set)

Class: **A50-X** Cat. no. **IS01**

Designed for:

Manufacturer: **ISUZU**

Model: **D-MAX, bumper with a step**

produced since 01.2007 till 05.2012

Technical data:

**D-value: 14,6 kN**

maximum trailer weight: **3000 kg**

maximum vertical cup mass: **120 kg**

**Approval number according to Directive 94/20/EC: e20\*94/20\*0713\*00**

## Foreword

This towing hitch is designed according to rules of safety traffic regulations. The towing hitch is a safety component and can be install only by qualified personnel. Any alteration or conversion of the towing hitch is prohibited and would lead to cancellation of design certification. Remove insulating compound and underseal from vehicle (if present) in the area of the matting surfaces of the towing hitch. The vehicle manufacturer's specifications regarding trailer mass and max. vertical cup mass are decisive for driving whereat values for the towing hitch cannot be exceeded.

*D-value formula:*

$$\frac{\text{Max trailer weight [kg]} \times \text{Max vehicle weight [kg]}}{\text{Max trailer weight [kg]} + \text{Max vehicle weight [kg]}} \times \frac{9,81}{1000} = D \text{ [kN]}$$