

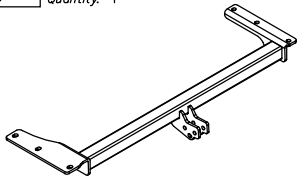

Towing hitch accessories:

Pos. 1	Name: Main bar Quantity: 1	Pos. 5	Name: Left fish-plate Quantity: 1	Pos. 10	Name: Nut 8 B Quantity: 6 Dim. : M10
		Pos. 6	Name: Distance sleeve Quantity: 6 Dim. : Ø21.3x2.65 L=60mm	Pos. 11	Name: Plain washer Quantity: 2 Dim. : Ø 13 mm
Pos. 2	Name: Tow ball Quantity: 1	Pos. 7	Name: Bolt 8,8 B Quantity: 2 Dim. : M12x75mm	Pos. 12	Name: Plain washer Quantity: 6 Dim. : Ø 10,5 mm
Pos. 3	Name: Socket plate Quantity: 1	Pos. 8	Name: Bolt 8,8 B Quantity: 6 Dim. : M10x90mm	Pos. 13	Name: Spring washer Quantity: 2 Dim. : Ø 12,2 mm
Pos. 4	Name: Right fish-plate Quantity: 1	Pos. 9	Name: Nut 8 B Quantity: 2 Dim. : M12	Pos. 14	Name: Spring washer Quantity: 6 Dim. : Ø 10,2 mm
		Pos. 15	Name: Ball cover Quantity: 1		



PPUH AUTO-HAK Sp.J.

Produkcja Zaczepów Kulowych
Henryk & Zbigniew Nejman
76-200 SŁUPSK ul. Słoneczna 16K
tel/fax (059) 8-414-414; 8-414-413
E-mail: office@autohak.com.pl
www.autohak.com.pl

Towing hitch (without electrical set)

Class: **A50-X** Cat. no. **E08**

Designed for:

Manufacturer: **OPEL**

Model: **ASTRA (F)**

Type: **4 doors**

produced since 09.1991 till 2002

Technical data:

D-value: 7,55 kN

maximum trailer weight: **1500 kg**

maximum vertical cup load: **75 kg**

Approval number acc. to regulations EKG/ONZ 55.01: E20-55R-01 0852

Foreword

This towing hitch is designed according to rules of safety traffic regulations. The towing hitch is a safety component and can be install only by qualified personnel. Any alteration or conversion of the towing hitch is prohibited and would lead to cancellation of design certification. Remove insulating compound and underseal from vehicle (if present) in the area of the matting surfaces of the towing hitch. The vehicle manufacturer's specifications regarding trailer mass and max. vertical cup mass are decisive for driving whereat values for the towing hitch cannot be exceeded.

D-value formula:

$$\frac{\text{Max trailer weight [kg]} \times \text{Max vehicle weight [kg]}}{\text{Max trailer weight [kg]} + \text{Max vehicle weight [kg]}} \times \frac{9,81}{1000} = D \text{ [kN]}$$

FITTING INSTRUCTION

Clamp mark in acc. with		Cables joining
ISO	PN	
1	L	Left directional lights
2	+	Rear fog lights
3	31	Ground
4	R	Right directional lights
5	58R	Right side parking lights
6	54	Stoplights
7	58L	Left side parking lights

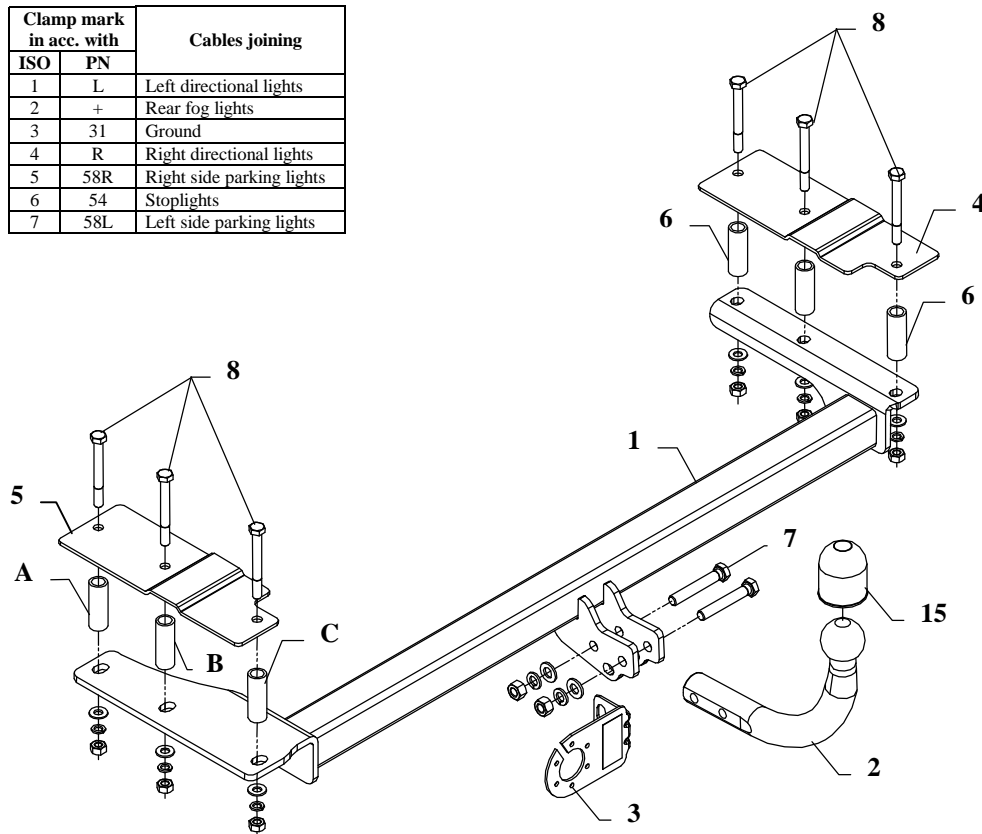

This towing hitch is designed to assembly in following cars:
OPEL ASTRA (F), 4 doors , produced since 09.1991 till 2002, catalogue no. **E08** and is prepared to tow trailers max total weight **1500 kg** and max vertical load **75 kg**.

From manufacturer

Thank you for buying our product. Their reliability has been confirmed in many tests. Reliability of towing hitch depends also on correct assembly and right operation. For this reasons we kindly ask to read carefully this instruction and apply to hints.

The towing hitch should be install in points described by a car producer.

The instruction of the assembly

1. Find a fabric signed holes, then drill 3 holes $\varnothing 11$ mm. It will be easier to find these holes if you position an elements (pos. 4 and 5).
2. Position the main bar of the towing hitch (pos. 1) to a chassis (slide an fabric towing eye on the right side), at the same time put a distance sleeves (pos. 6) to the chassis members holes (do it in the following order: A, B, C).
3. Through the elements (pos. 4 and 5), the sleeves and the main bar of the towing hitch (pos. 1) fix it using a bolts M10x90mm – pos. 8 (do it inside the boot).
4. Fix a towball (pos. 2) with the socket plate (pos. 3) to the mounted bar of the towing hitch (pos. 1) with M12x75mm (pos. 7).
5. Tighten all nuts and bolts according to the torque shown in the table.
6. Connect the electric wires according to the instructions of the car.
7. Complete the paint cover of towbar (during the mounting paint cover could be destroyed).

Torque settings for nuts and bolts (8,8):

M6 - 11 Nm	M 8 - 25 Nm	M 10 - 50 Nm
M 12 - 87 Nm	M 14 - 138 Nm	M16 - 210 Nm

NOTE

After installation of a towing hitch you should get adequate note in registration book (at authorised service station). The car should be equipped with:

- Indicators
- Tow mirrors

After 1000km of exploitation check all bolts and nuts. The ball of towing hitch must be always kept clear and conserve with a grease.