

FITTING INSTRUCTION

Clamp mark in acc. with		Cables joining
ISO	PN	
1	L	Left directional lights
2	+	Rear fog lights
3	31	Ground
4	R	Right directional lights
5	58R	Right side parking lights
6	54	Stoplights
7	58L	Left side parking lights

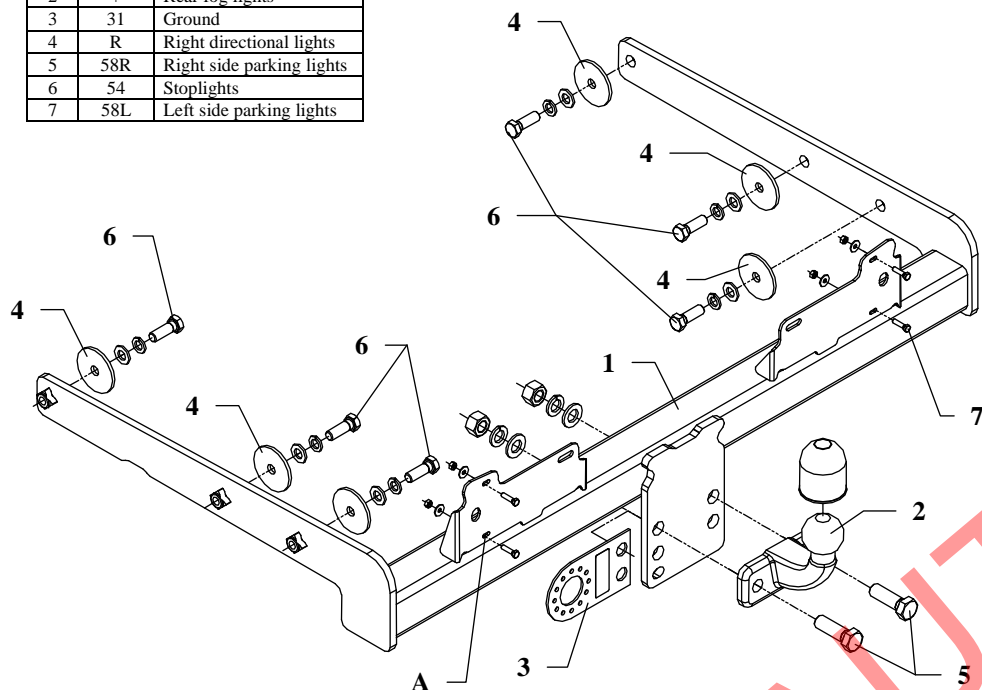

This towing hitch is designed to assembly in following cars: **VOLKSWAGEN T4 TRANSPORTER, loading platform**, produced since 09.1990 till 12.2002, catalogue no. **K28** and is prepared to tow trailers max total weight **2500 kg** and max vertical mass **100 kg**.

DE PRODUCATOR:

Vă mulțumim pentru achiziționarea produsului nostru. Fiabilitatea acestor produse a fost confirmată în numeroase teste. Fiabilitatea produselor depinde de asemenea și de asamblarea corectă și în ordinea specificată în aceste instrucțiuni. Din acest motive va rugăm să citiți cu atenție instrucțiunile și să le urmați întocmai. Bara de tractare trebuie să fie instalată în punctele descrise de producătorul autovehiculului.

The towing hitch should be install in points described by a car producer.

The instruction of the assembly

1. For the purpose of installings of the towing hitch one ought to unscrew the number plate and little lamps which light up it.
2. Slip the main bar of the towing hitch (pos. 1) into the frame of the car and fix it through the factory-made holes using bolts M12x35mm (pos. 6) from the towing hitch accessories (use washers $\varnothing 58 \times 12.5 \times 4$ mm - pos. 4).
3. Fix tow ball (pos. 2) using bolts M16x50mm (pos. 5). One from these bolts fix also the socket plate (pos. 3) in accordance with the drawing.
4. Fix the number plate along with little lamps through holes (pos. A) of the towing hitch.
5. Tighten all bolts according to the torque shown in the table.
6. Connect electric wires of 7-poles socket according to the instruction of the car. (Recommend to make at authorized service station).
7. Complete paint layer damaged during installation.

Torque settings for nuts and bolts (8,8):

M6 - 11 Nm	M8 - 25 Nm	M10 - 50 Nm
M12 - 87 Nm	M14 - 138 Nm	M16 - 210 Nm











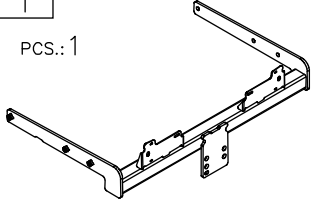
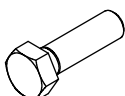

NOTE

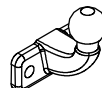
After install the towing hitch you should get adequate note in registration book (at authorised service station). The car should be equipped with:

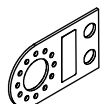
- Indicators
- Tow mirrors

After 1000km check all bolts and nuts. The ball of towing hitch must be always kept clear and conserve with a grease.

Towing hitch accessories:

Pos. 1 Main bar PCS.: 1 	Pos. 5 Bolt 8,8 B M16x50mm PCS.: 2 	Pos. 10 Plain washer ø17mm PCS.: 2 
	Pos. 6 Bolt 8,8 B M12x35mm PCS.: 6 	Pos. 11 Plain washer ø13mm PCS.: 6 
Pos. 2 Tow ball PCS.: 1 	Pos. 7 Bolt 8,8 B M5x20mm PCS.: 4 	Pos. 12 Plain washer ø15xø5.3x1.2 PCS.: 4 
Pos. 3 Socket plate PCS.: 1 	Pos. 8 Nut 8 B M16 PCS.: 2 	Pos. 13 Spring washer ø16.3mm PCS.: 2 
Pos. 4 Washer ø58xø12.5x4 PCS.: 6 	Pos. 9 Nut 8 B M5 PCS.: 4 	Pos. 14 Spring washer ø12.2mm PCS.: 6 
	Pos. 15 Ball cover PCS.: 1 	



S.C. AUTO GEDAL IMPEX S.R.L.

Tel: +40 745.805.990 / +40 737.122.471

Email: autogedal@gmail.com

office@auto-hak.ro

Web Page: www.auto-hak.ro

Carlig remorcare Volkswagen T4-Transporter 1990-2002 semidemontabil Auto-Hak

Class: **A50-X** Cat. no. **K28**

Designed for:

Manufacturer: **VOLKSWAGEN**

Model: **T4 TRANSPORTER**

Type: **loading platform**

produced since 09.1990 till 12.2002

Technical data:

D-value: 12,9 kN

maximum trailer weight: **2500 kg**

maximum vertical cup mass: **100 kg**

Approval number according to Directive 94/20/EC: e20*94/20*0393*00

Acesta bara de tractare este proiectata în conformitate cu normele de siguranță ale regulilor de circulație. Carligul de tractare este o componentă de siguranță și poate fi instalata numai de personal calificat. Orice modificare sau transformare facuta asupra cârligului de remorcare este interzisă și va duce la anularea certificării produsului. Indepartați materialul izolator de sub vehicul (dacă există) in zona de montare a ansamblului. Specificatiile de produs ale autovehiculului referitor la greutatea admisa pe vehicul, sunt extrem de importante. In acelasi timp, sarcina admisa pentru cârligul de remorcare nu poate fi depășită si poate fi calculata folosind relatia:

$$\frac{\text{Masa maxima a remorcii [kg]} \times \text{Masa maxima a masinii[kg]}}{\text{Masa maxima a remorcii [kg]} + \text{Masa maxima a masinii[kg]}} \times \frac{9,81}{1000} = D \text{ [kN]}$$